



URSA GLASSWOOL®



E-mail : ursauk@uralita.com

URSA UK LTD
Crest House
102-104 Church Road
Teddington, Middlesex TW11 8PY
United Kingdom
Tel : 020 8977 96 97
Fax : 020 8977 94 56
Web : www.ursa-uk.co.uk

URSA 20 Plus and URSA 20 Insulation for Built-up Metal Cladding Systems

The Company

As a leading supplier of insulation and insulating systems, **URSA** has succeeded in fully addressing user requirements for thermal and acoustic insulation. Quality products for every application and excellent customer support are the cornerstones of the corporate culture.

URSA is the number two manufacturer of glass wool and extruded polystyrene products in Europe and in terms of sales, the largest business unit of the URALITA Group.

The **URALITA** Group is a Spanish multinational company that started operations in 1907 and is therefore one of the oldest companies in the European building materials industry. With 37 production sites in 11 countries, the **URALITA** Group generated sales of €700 million in 2009. The other three Building Materials divisions (Gypsum, Roofing and Piping Systems) and the Chemicals division of the Group are leaders in the southern European markets.

At 14 production sites **URSA** has more than 1,800 employees generating sales revenues of over €400 million.

URSA GLASSWOOL® is manufactured in Spain, France and Belgium, at two sites in Germany, in Slovenia, Hungary and Poland as well as in two Russian plants. Our closely-woven network of sales offices stretches across Europe and Russia. Almost everywhere **URSA** is amongst the market leaders. In Russia and in a number of other Eastern European countries, we are number one in the glasswool segment. We have also enjoyed a strong position particularly on the growth markets of the new EU partner countries from the very beginning.

URSA 20 Cladding Roll

URSA 20 Cladding Roll is a lightweight, non-combustible, unfaced glass mineral wool product for use in built-up metal wall and roof cladding systems.

It has a thermal conductivity of 0.037 W/mK (**URSA 20 Plus**) or 0.040 W/mK (**URSA 20**).

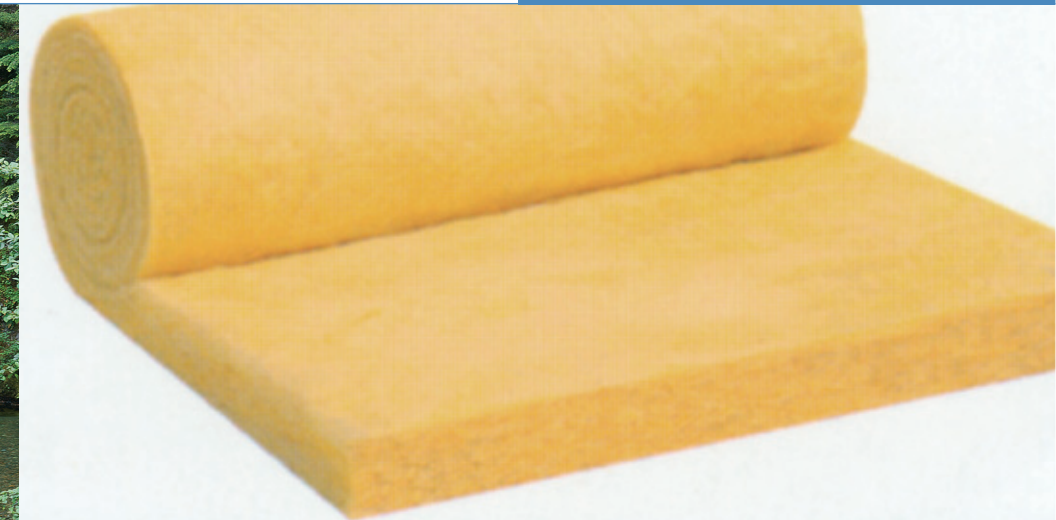

Benefits

Quality

Outstanding product quality manufactured to ISO 9001 Quality Systems.

Ozone friendly

Glass wool products do not contain or use in their manufacture ozone depleting chemicals such as CFCs and HCFCs. The Ozone Depletion Potential (ODP) is zero.

Global warming potential

URSA 20 Cladding Roll does not use chemical blowing agents and so the Global Warming Potential (GWP) arising from it is zero.

Insulation savings

It is possible to meet the Building Regulation requirement with 160mm of **URSA 20 Cladding Roll**.

Cost effective

Rapid and simple construction means this is a very cost effective way of insulating new buildings or upgrading existing.

Acoustics

URSA 20 Cladding Roll has excellent sound insulation characteristics and enhances the acoustic comfort of the building.

Environment

Glass wool is manufactured from an abundant, sustainable resource and may utilise up to 80% post consumer glass waste.

Fire Performance

URSA 20 Cladding Roll is classed as non-combustible.

Handling

URSA 20 Cladding Roll is lightweight yet tough, resilient and easy to install. It is easily cut using a sharp knife.

Space saving

Compaction of the rolls in their manufacture saves space in both storage and transport.

Durability

URSA 20 Cladding Roll is rot-proof, durable and maintenance free. It is non-hygroscopic and will not slump in normal use.

All of our products carry the CE Mark to show compliance with the harmonised European Standard BS EN 13162 and are quality assured to ISO 9001.



Design

Metal roofing and cladding systems comprise an inner liner tray with spacer brackets and sheeting rails onto which is fixed the external cladding (See Figure 1). The space created by the brackets and rails is used to accommodate the mineral fibre insulation. Due to the nature of this type of construction there are a number of specific design considerations that must be accounted for - detailed design advice is available from the Metal Cladding and Roofing Manufacturers Association (MCRMA) and the Steel Construction Institute (SCI). The following summarises the critical features.

Figure 1 – General Roof Detail

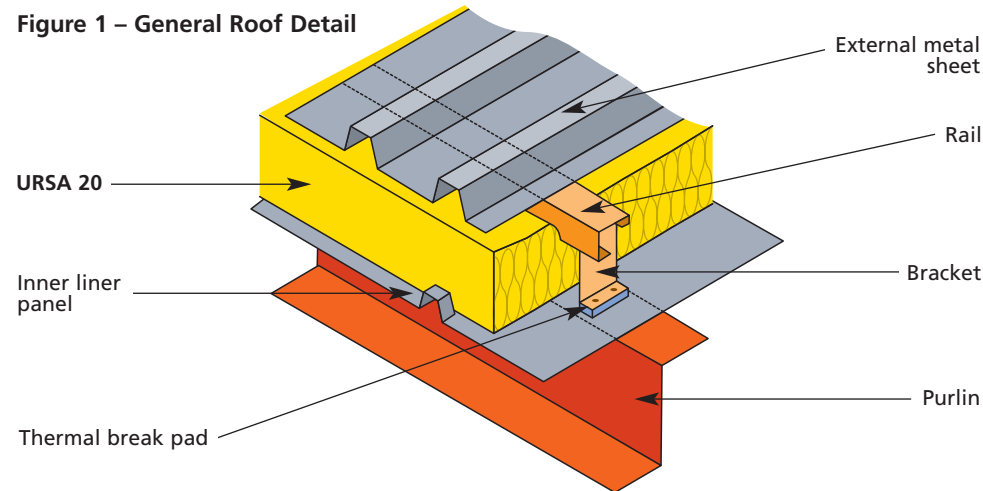

Spacer Brackets

The metal spacer brackets penetrate the thickness of the insulation and introduce a considerable amount of thermal bridging. The brackets should incorporate a thermal break to minimise this effect.

Thermal Bridging

With increasing levels of insulation it is vitally important to ensure continuity of the insulation at the junction of elements. The full insulation thickness should be maintained throughout the whole wall or roof area with special care taken at corners, junctions and around openings. The insulation should be tightly butted together to allow the fibres to 'knit' and prevent any gaps.

Limiting Air Infiltration

Unwanted and uncontrolled air infiltration is a major source of heat loss. The Building Regulations now place limits on the air infiltration rate which must be measured on the completed building. Simple measures include sealing the laps in the inner liner sheet, incorporating an air infiltration barrier (the vapour control layer may perform this function) and sealing gaps around penetrations and openings.

Condensation

With increasing levels of insulation the increased risk of interstitial condensation must be carefully considered – BS 5250 gives detailed design advice. Measures that should be taken include:

- Removal of the water vapour at source by the use of suitable ventilation and/or extract fans in high humidity areas.
- The use of a correctly detailed and carefully sealed vapour control layer (formed either by sealing the laps in the liner tray or providing a minimum 500g polythene sheet) to reduce the amount of water vapour from the habitable area passing into the cold void above the insulation. The vapour control layer should be continuous with special care being taken at the junctions of elements and around openings and penetrations.
- Provide ventilation above the insulation to remove any moisture laden air. BS 5250 recommends that the voids of the external cladding should be ventilated at both ends with ventilated fillers giving a minimum opening of not less than 5% of the sheet void above the rails. Ensure that birds, insects and vermin cannot enter via the vents.

Acoustics

Figure 2 – Acoustic Systems

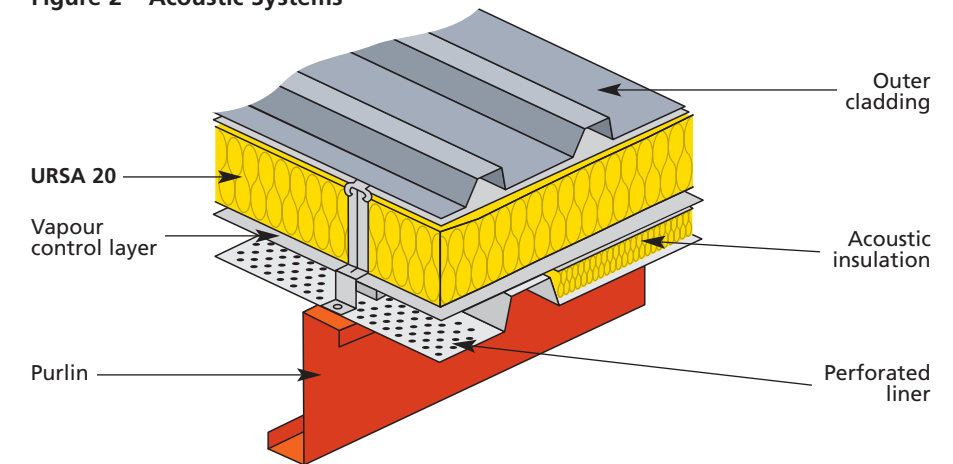

- Sheet metal cladding and roofing may suffer intermittent condensation problems on clear, cloudless nights due to clear night sky radiation. This causes the metal cladding to fall to a temperature considerably below the ambient temperature producing condensation on the underside of the external cladding. The use of a breather membrane should be considered to allow any droplets of condensate to drain away to the gutters.

Design Loadings

The load exerted on the cladding will vary according to geographical location, site location and building height. Calculations relating to the bracket and rail fixing pattern should be made with reference to BS EN 1991, Eurocode 1; Actions on Structures.

Fire Performance

When used within a cladding system constructed in accordance with this brochure URSA 20 Cladding Roll will enhance the fire resistance properties of the roof or wall achieving up to 60 minute fire resistance. Generally the profiled cladding will achieve the best external fire rating of EXT.SAA (sloping roofs) or EXT.FAA (flat roofs). Fire stopping in the form of mineral fibre insulation should be used at party/separating walls.

Acoustics

Lightweight roof and wall cladding systems can readily transmit sound.

URSA 20 Cladding Roll has excellent acoustic properties which can reduce the overall sound transmission to acceptable levels.

This works in two ways; either keeping noise from inside the building (for example a factory environment) from annoying nearby residents or by preventing noise pollution from outside the building (e.g. a nearby motorway or airport). Similarly mineral fibre insulation may be used to control the acoustic performance inside the building. Large, open plan buildings may suffer excessive sound reverberation which can be controlled by suitable mineral fibre linings.

A perforated inner liner tray allows sound energy to penetrate and be absorbed and dissipated by the mineral fibre within the roof or wall structure. Typically this detail includes a relatively thin layer of tissue faced mineral fibre as the acoustic insulation followed by the vapour control layer and main thickness of (thermal) insulation (See Figure 2).



Installation

Figure 3 – Bracket & Rail Systems

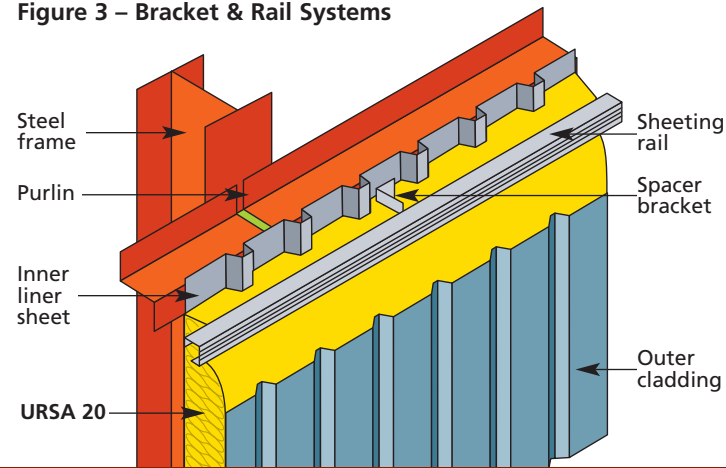

Figure 4 – Wall Detail (horizontal cladding)

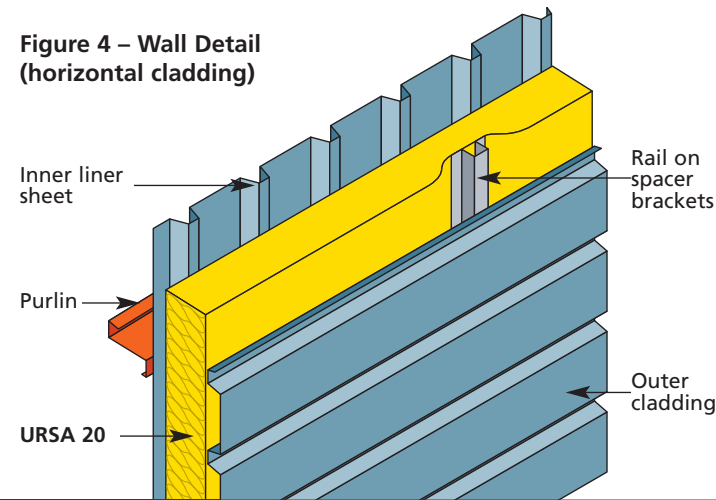

Figure 5 – Roof Detail

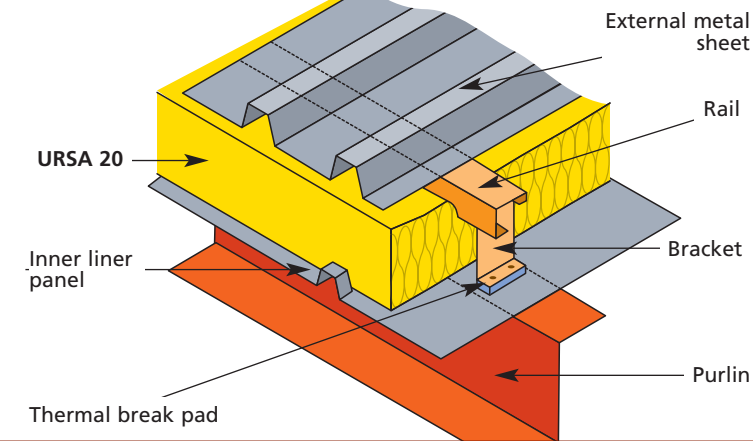
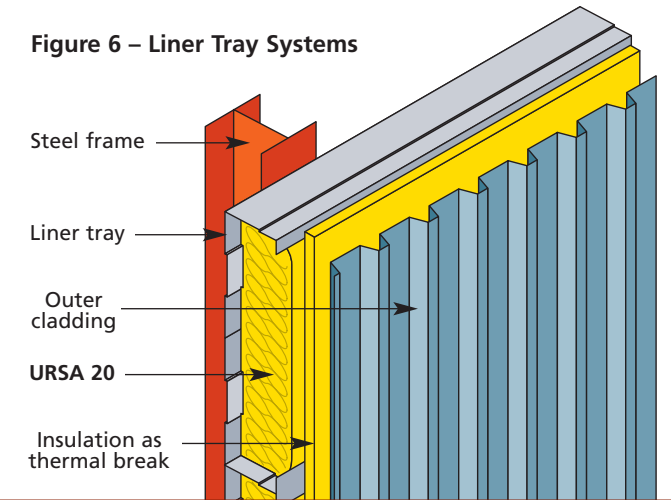

Figure 6 – Liner Tray Systems



Bracket & Rail Systems (See Figures 3, 4 and 5)

URSA 20 Cladding Roll is designed to be laid on the inner lining sheet and held in place by the spacer brackets and sheeting rails.

The usual procedure for construction is:

1. The structural framing, inner liner sheet, metal spacer brackets (with thermal break) and sheeting rails are installed in accordance with the relevant manufacturer's instructions.
2. A polythene vapour control layer, if required, is fixed on the liner with all joints lapped and sealed with special care being taken at the junction of elements. Alternatively the laps in the inner liner sheet may all be sealed to create the vapour control layer.
3. The URSA 20 Cladding Roll is laid on the inner liner sheet ensuring there are no gaps in the insulation, around the brackets or around openings and penetrations. The insulation is slid under the sheeting rails where it will be slightly compressed.
4. If required a breather membrane is laid over the insulation prior to installing the external sheeting.
5. The profiled external sheeting should be installed as soon as possible after laying the URSA 20 Cladding Roll to avoid exposure to the weather. Lay only sufficient insulation that can be covered and protected on the same working day, otherwise provide temporary protection. Provide temporary protection during bad weather including rain, wind and snow or freezing conditions.
6. Ensure that any penetrations through the ceiling, especially if formed by following trades, are correctly sealed to ensure an air and vapour tight ceiling.

Liner Tray Systems (See Figure 6)

URSA 20 Cladding Roll is designed to be laid in the liner tray and held in place by the external cladding.

The usual procedure for construction is:

1. The structural framing and inner liner tray (with thermal break) are installed in accordance with the relevant manufacturer's instructions.
2. The laps and joints in the liner tray should all be sealed to create the vapour control layer.
3. The URSA 20 Cladding Roll is laid in the liner tray ensuring there are no gaps in the insulation or around openings and penetrations.
4. If required, a breather membrane is laid over the insulation prior to installing the external sheeting.
5. The profiled external sheeting should be installed as soon as possible after laying the URSA 20 Cladding Roll to avoid exposure to the weather. Fit only sufficient insulation that can be covered and protected on the same working day, otherwise provide temporary protection. Provide temporary protection during bad weather including rain, wind and snow or freezing conditions.
6. Ensure that any penetrations through the wall, especially if formed by following trades, are correctly sealed to ensure an air and vapour tight ceiling.



Suspended Ceiling

Heat Loss Calculations

The normal method of calculating U-values in floors, walls and roofs is the Combined Method (see BS EN ISO 6946). This method cannot be used with metal cladding systems however as the heat loss pattern is considerably more complex due to the metal spacer brackets and sheeting rails. Reference must be made instead to document P312, Metal Cladding: U-value Calculation, from the Steel Construction Institute (SCI) which gives a simplified method of either calculating the U-value from first principles or estimating it from graphs. For systems that use Z-spacers refer to BRE Information Paper IP 10/02: Metal cladding: assessing the thermal performance of built-up systems using Z-spacers.

Figure 7 – Suspended Ceilings

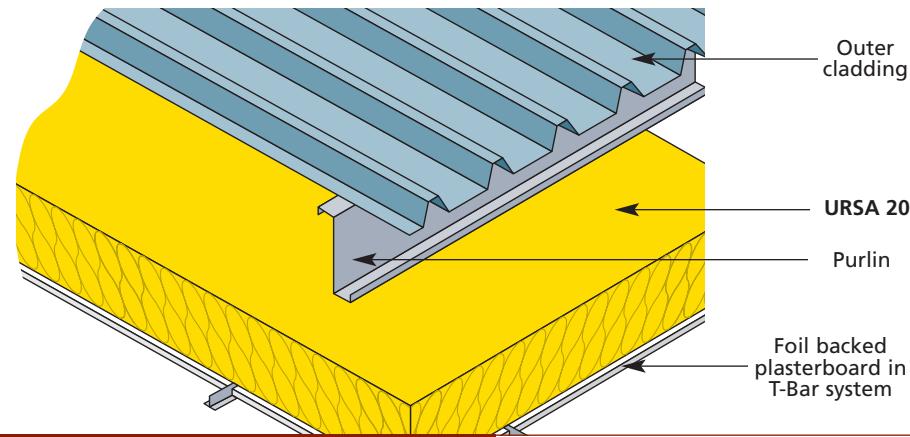

URSA 20 Cladding Roll is designed to be laid above the foil backed plasterboard ceiling.

The usual procedure for construction is:

1. The structural framing and cladding system are installed in accordance with the relevant manufacturer's instructions.
2. The support system for the plasterboard ceiling such as a T-bar system suspended from the structural frame (fixed in accordance with the manufacturer's instructions) or timber battens is then installed.
3. Fix foil backed plasterboard to the support system and correctly seal any joints.
4. The URSA 20 Cladding Roll is laid on the plasterboard ceiling ensuring there are no gaps in the insulation, around the suspension wires or around openings and penetrations.
5. Ensure that any penetrations through the ceiling, especially if formed by following trades, are correctly sealed to ensure an air and vapour tight ceiling.

Compliance with the Building Regulations is shown by limiting the overall CO₂ emissions from the building – this gives considerable design flexibility but there are no specific U-values, except the worst allowable, that must be achieved.

To summarise the requirements:

Walls

In new build a U-value of 0.25 W/m²K or better will help ensure compliance. In extensions a U-value of 0.28 W/m²K is required and in refurbishment work 0.30 W/m²K is required. The Building Regulations (Scotland) require a U-value of 0.25 W/m²K or better.

Roofs

In new build a U-value of 0.16 W/m²K or better will help ensure compliance. In extensions and refurbishment work a U-value of 0.18 W/m²K is required.

Typical Construction

0.7mm profiled steel outer sheet.

URSA 20 Cladding Roll.

0.4mm profiled steel inner sheet.
0.56 spacer brackets per square metre.
60mm² cross sectional area.
Conductivity 60 W/mK.

C Section rails @ 1200mm c/c.
40mm depth. 40mm width.
Conductivity 60 W/mK.

URSA 20 Plus Metal Cladding Insulation

URSA 20 Plus (mm)	Wall U-Value (W/m ² K)	Roof U-Value (W/m ² K)
100	0.40	0.40
120	0.33	0.33
140	0.29	0.30
160	0.25	0.25
180	0.23	0.23
200	0.20	0.21
220*	0.18	0.18
240*	0.16	0.16
260*	0.15	0.15
280*	0.14	0.14

* Double layer systems

URSA 20 Metal Cladding Insulation

URSA 20 (mm)	Wall U-Value (W/m ² K)	Roof U-Value (W/m ² K)
100	0.42	0.43
120	0.35	0.36
140	0.31	0.31
160	0.27	0.27
180	0.24	0.24
200	0.22	0.22
220*	0.19	0.19
240*	0.17	0.18
260*	0.16	0.16
280*	0.15	0.15

* Double layer systems

These values are indicative only as each system will be slightly different depending upon the exact system specification. For the U-value of other wall or roof details please contact URSA UK Technical Services or your cladding system manufacturer.

Technical Details

Specification Clause

The cladding insulation shall bemm thick **URSA 20 Plus/URSA 20** glass wool insulation. The insulation is positioned on the inner liner sheet and between/under the spacer brackets and cladding rails. The insulation is to be installed as work proceeds in accordance with URSA UK Ltd instructions and MCRMA Technical Papers.

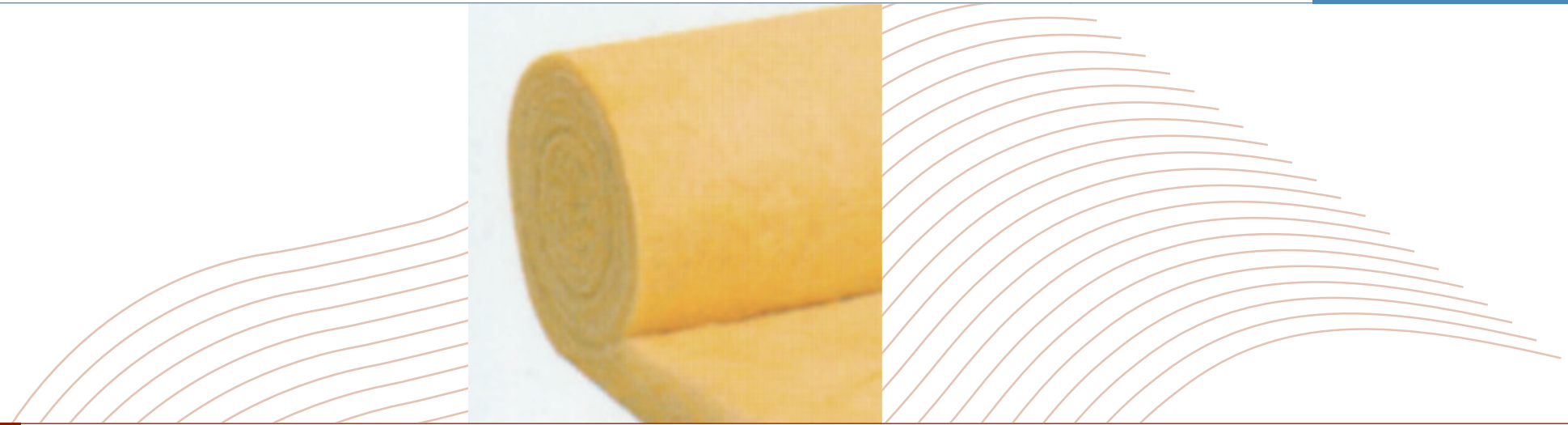

Thermal Conductivity

The declared thermal conductivity, λ_D -value, of **URSA 20 Plus** is 0.037 W/mK and for **URSA 20** it is 0.040 W/mK when tested to BS EN 13162.

Density

Nominal density for **URSA 20 Plus** is 18 kg/m³ and for **URSA 20** it is 12 kg/m³.

Reaction to Fire

Euroclass A1 to BS EN 13501-1.

Moisture Vapour Transmission

URSA 20 Cladding Roll has minimal resistance to the passage of water vapour, thus allowing the roof to breathe.

A practical value for the moisture vapour resistivity is 5 MNs/gm.

Specific Heat Capacity

The specific heat capacity is 0.84 kJ/kgK.

Designation Code

MW – EN 13162 – T1 – DS(T+) – MU1

Dimensions

URSA 20 Plus Cladding Roll

Thickness (mm)	Length (m)	Width (mm)	Pack Size (m ²)
100	5.5	1200	6.60
120	4.5	1200	5.40
140	4.0	1200	4.80
160	3.5	1200	4.20
180	3.0	1200	3.60
200	2.7	1200	3.24

URSA 20 Cladding Roll

Thickness (mm)	Length (m)	Width (mm)	Pack Size (m ²)
60	12.0	1200	14.40
80	10.0	1200	12.00
90	9.0	1200	10.80
100	8.0	1200	9.60
120	6.0	1200	7.20
140	5.0	1200	6.00
160	5.0	1200	6.00
180	5.0	1200	6.00
200	4.0	1200	4.80

Environmental Information

BRE Green Guide

All URSA glass wool products achieve the best possible 'A+' rating under the BRE Green Guide.

Durability

When correctly installed, **URSA 20 Cladding Roll** is maintenance free and has an indefinite life at least equal to that of the building.

Storage

URSA 20 Cladding Roll is supplied wrapped in polythene to provide short-term protection. On site the rolls should be stored clear of the ground, on a clean level surface and under cover to protect them from prolonged exposure to moisture or mechanical damage.

Chemical Compatibility

URSA 20 Cladding Roll is compatible with all common construction materials, alkalis, dilute acids, mineral oil and petrol. Products that have been in contact with harsh solvents, acids or saturated with water should not be used.

Health and Safety

URSA 20 Cladding Roll is inherently safe to handle. During cutting or handling any dust generated is of nuisance value only; the wearing of dust masks, gloves and long sleeved clothing is recommended. Large scale machining should be connected to a dust extraction system. A comprehensive Health and Safety data sheet is available from URSA UK Ltd upon request.

Availability

URSA 20 Cladding Roll is available nationally through insulation distributors and builders merchants.

References

The Building Regulations and supporting documents.

Thermal Insulation: avoiding risks (2002).

Limiting Thermal Bridging and Air Leakage: Robust Construction Details for Dwellings and Similar Buildings (DTLR/DEFRA).

Design Guide for Metal Roofing & Cladding to Comply with Energy Requirements of UK Building Regulations 2006 -Technical Paper 17 (MCRMA).

Metal Wall Systems Design Guide - Technical Paper 5 (MCRMA).

Profiled Metal Roofing Design Guide - Technical Paper 6 (MCRMA).

Metal Cladding: U-value Calculation - P312 (Steel Construction Institute).

BRE Information Paper IP 10/02: Metal cladding: assessing the thermal performance of built-up systems using Z- spacers (BRE).

CIBSE Guide A3 - Thermal Properties of Building Structures.

BS 5427 Code of Practice for the use of Profiled Sheet for Roof and Wall Cladding on Buildings.

BS 5250 Code of Practice for Control of Condensation in Buildings.

BS EN 1991, Eurocode 1; Actions on Structures.

MCRMA Technical Papers, BRE Digests, Information Papers and Good Building Guides.